

CRE-EC

**Centrífugos de cubierta
de bajo consumo**

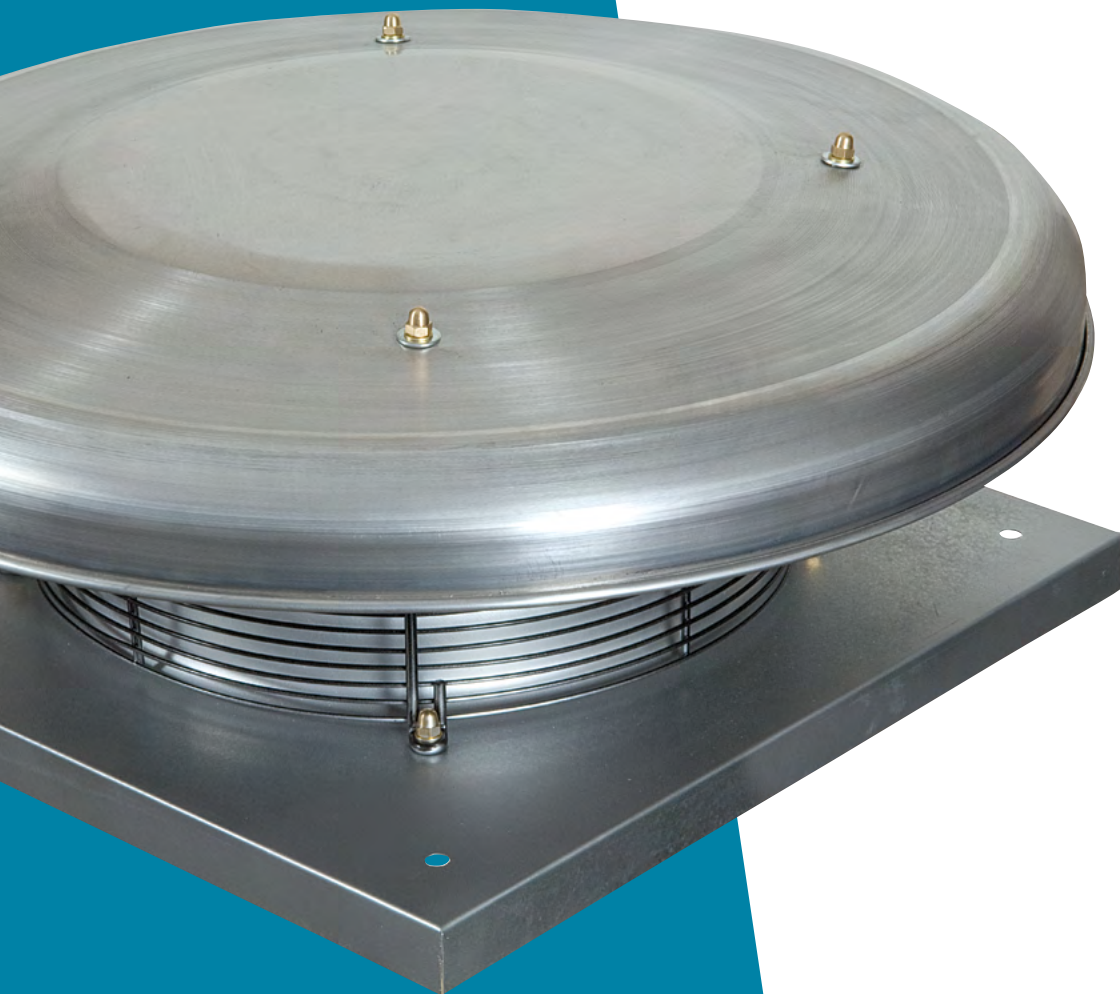

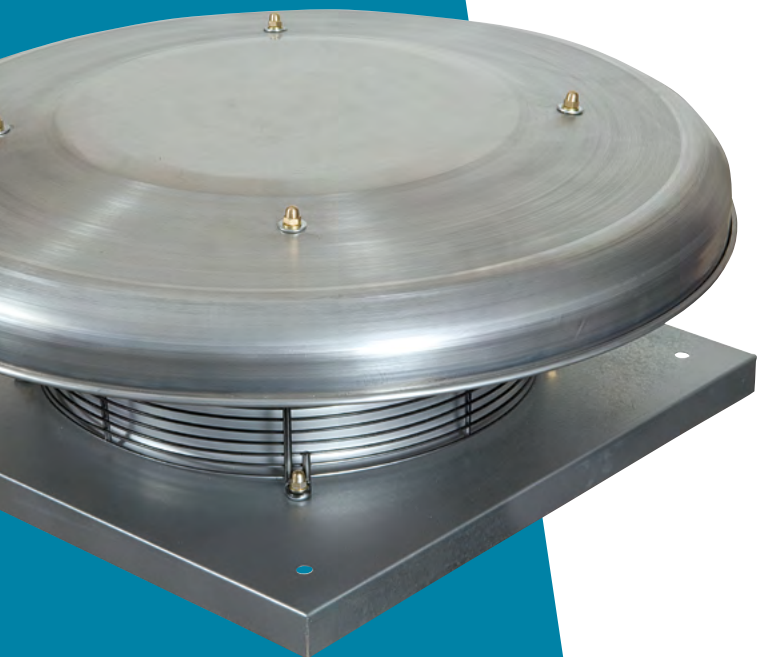

CRE-EC

Centrífugos de cubierta de bajo consumo

Serie de centrífugos, con motores de rotor externo, palas a reacción, del diámetro 130 al 630, con motores EC de bajo consumo, con entrada auxiliar 0-10 V.

CARACTERÍSTICAS

- Motores EC, S1, IP 54, clase B, rodamientos de bolas, entrada para señal externa 0-10 v de control, regulables. Electrónica de gestión integrada.
- Con reja anti pájaros, pintada.
- Capota de aluminio.
- Base de acero galvanizado.

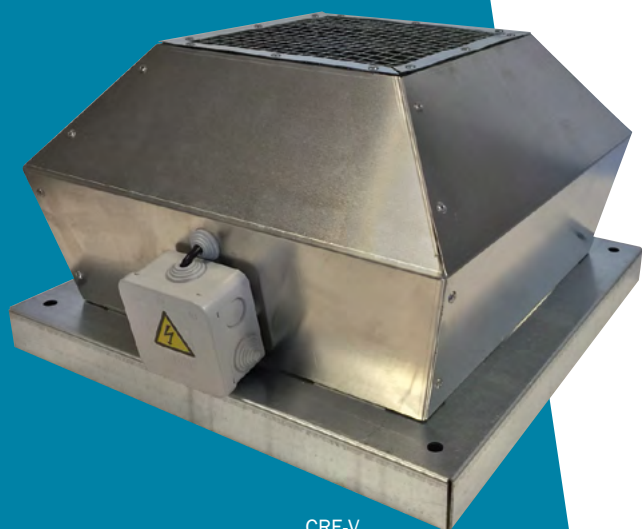

CRE-V



Diseño compacto



Motores EC de bajo consumo, con electrónica integrada

Fabricamos soluciones
innovadoras

NOVOVENT

■ Características técnicas

	Q max [m ³ /h]	Ø [mm]	U [V]	Pe [wW]	LpA [db(A)]	rpm
CRE 150 EC	732	133	~I/50Hz	0,027	63	3.770
CRE 200 EC	732	190	~I/50Hz	0,083	60	3.200
CRE 220 EC	997	220	~I/50Hz	0,085	60	2.585
CRE 250 EC	1.426	250	~I/50Hz	0,170	60	2.510
CRE 300 EC	2.335	280	~I/50Hz	0,168	62	1.910
CRE 310 EC	2.363	310	~I/50Hz	0,150	57	1.525
CRE 400 EC	4.383	400	~I/50Hz	0,250	64	1.170
CRE 450 EC	6.480	450	~I/50Hz	0,500	73	1.260
CRE 500 EC	8.668	500	~I/50Hz	0,750	66	1.100
CRE 560 EC	13.793	560	~III/50Hz	2,360	74	1.540
CRE 630 EC	16.771	630	~III/50Hz	2,700	73	1.300

Valores ErP

	CM	CE	SR	VSD	q [m ³ /s]	Ps [Pa]	Pe [W]	rpm	η	N'	η2015	N
CRE 150 EC							N/A					
CRE 200 EC							N/A					
CRE 220 EC							N/A					
CRE 250 EC	A	STATIC	1	YES	0,222	380	160	2.535	57,8	76,7	43,1	62
CRE 300 EC	A	STATIC	1	YES	0,389	240	160	1.775	64,4	83,3	43,1	62
CRE 310 EC	A	STATIC	1	YES	0,376	229	140	1.520	65,9	85,4	42,5	62
CRE 400 EC	A	STATIC	1	YES	0,665	223	250	1.170	66,4	83,2	45,2	62
CRE 450 EC	A	STATIC	1	YES	1,025	278	510	1.255	61,1	74,7	48,4	62
CRE 500 EC	A	STATIC	1	YES	1,396	308	740	1.100	63,1	75,0	50,1	62
CRE 560 EC	A	STATIC	1	YES	2,379	612	2.350	1.550	65,8	72,4	55,4	62
CRE 630 EC	A	STATIC	1	YES	3,101	553	2.760	1.305	65,7	71,6	56,1	62

■ Dimensiones (mm)

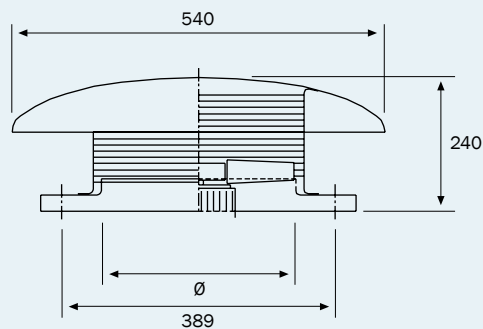

Curvas características

CRE 150 EC

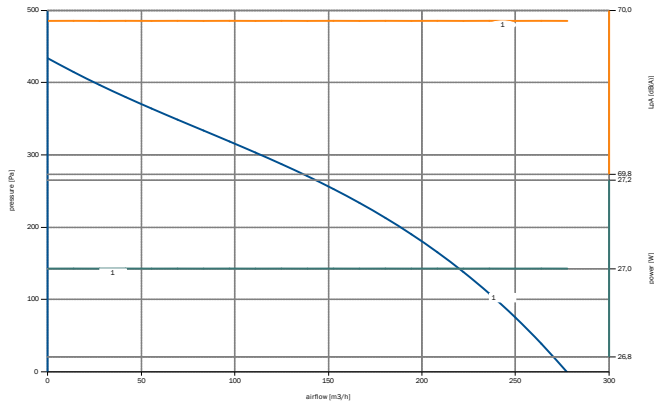

CRE 200 EC

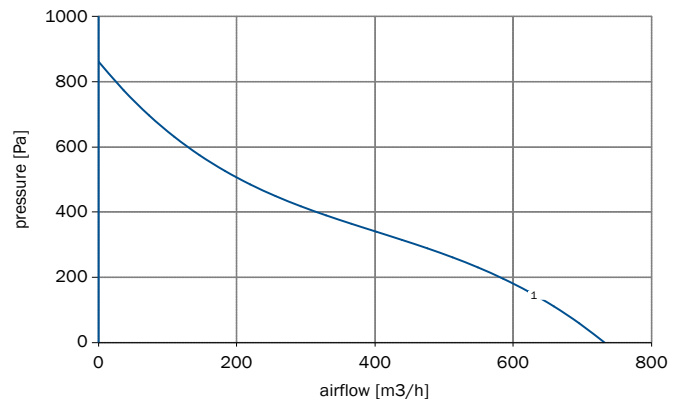

CRE 220 EC

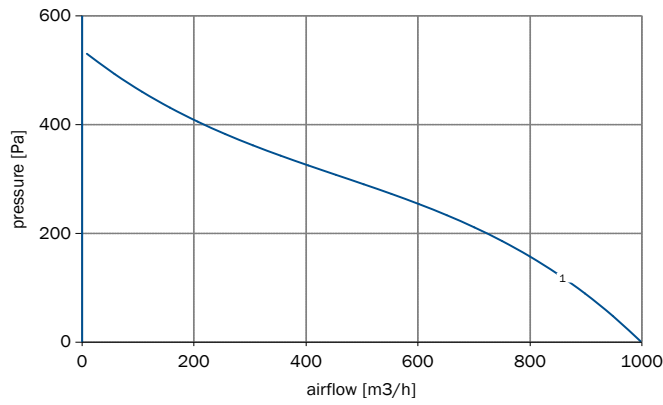

CRE 250 EC

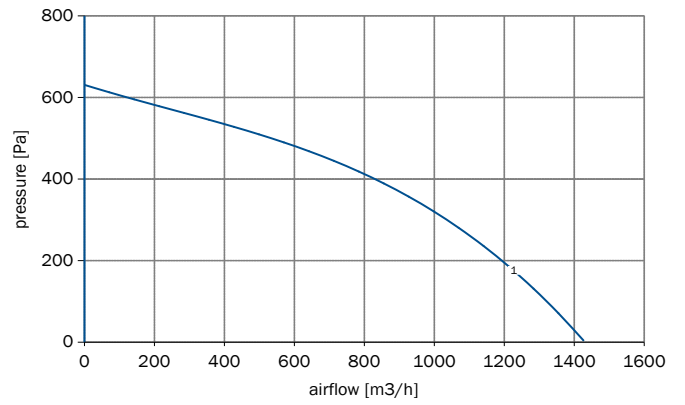

CRE 280 EC

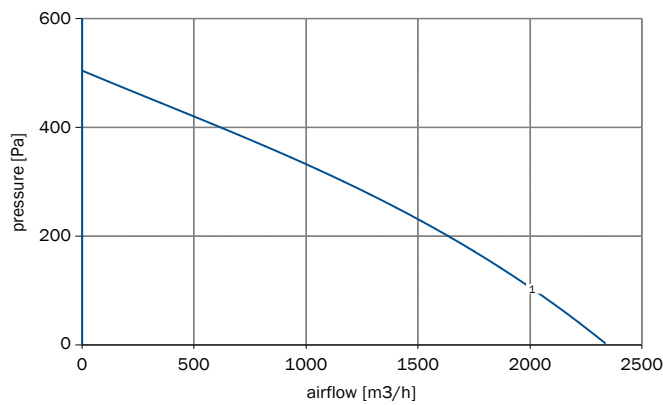

CRE 310 EC

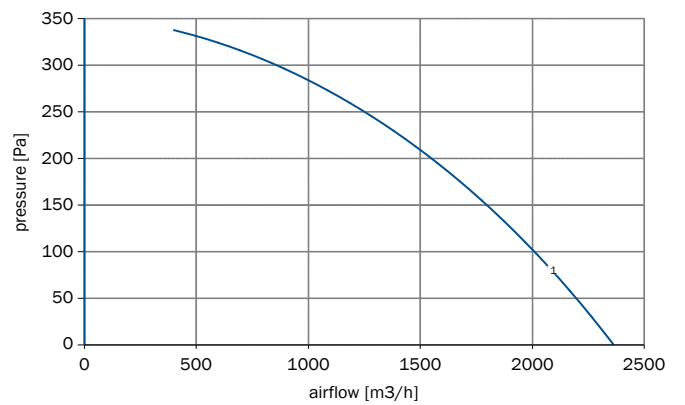

CRE 400 EC

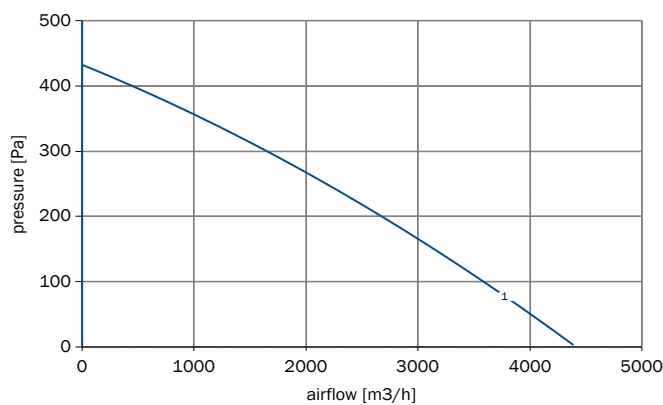

CRE 450 EC

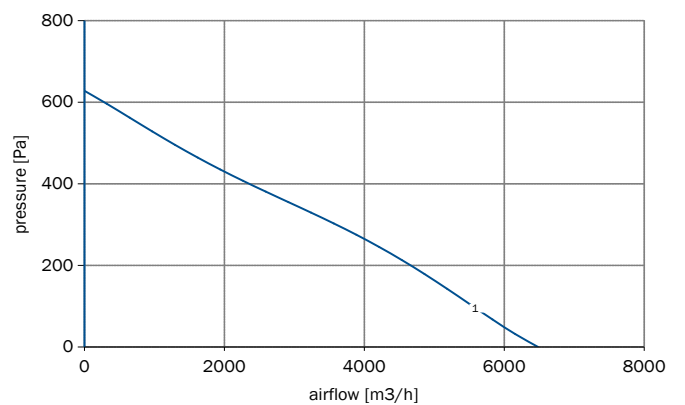

■ Curvas características

CRE 500 EC

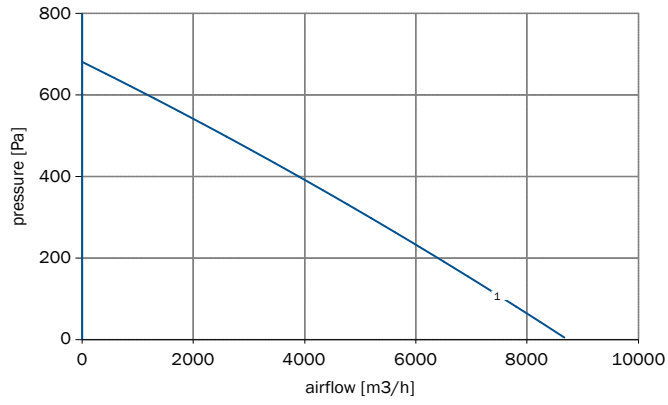

IN-NOVO 560 PLUS

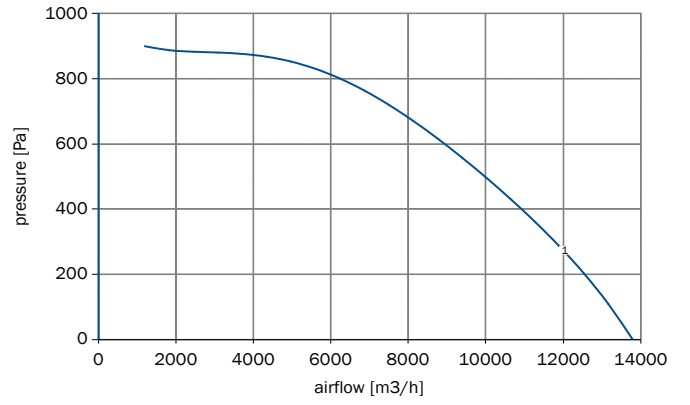

IN-NOVO 630 EC

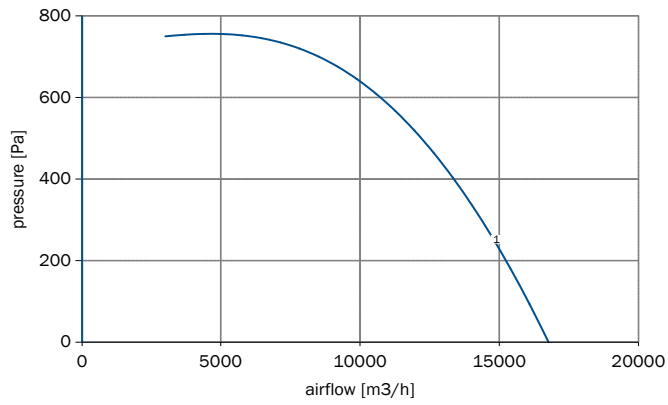



Fabricamos soluciones innovadoras

Josep Finestres, 9 · 08030 Barcelona · Tel. +34 93 278 82 77 · Fax +34 93 278 82 67
www.novovent.com · e-mail: novovent@novovent.com

